

Copy with Modified (cross out information)

Science Eight

Unit Three:

Light & Optical Systems

Name:

Date Received:

Date In:

Unit C: Light and Optical Systems

Outcome #1- Investigate the nature of light and vision; and describe the role of invention, explanation and inquiry in developing our current knowledge

Essential Outcomes (Ideas I must understand)	My Understanding			
<ul style="list-style-type: none"> identify challenges in explaining the nature of light and vision (<i>e.g., recognize that past explanations for vision involved conflicting ideas about the interaction of eyes and objects viewed; identify challenges in explaining upside-down images, rainbows and mirages</i>) 	1	2	3	4
<ul style="list-style-type: none"> investigate the development of microscopes, telescopes and other optical devices; and describe how these developments contributed to the study of light and other areas of science 	1	2	3	4
<ul style="list-style-type: none"> investigate light beams and optical devices, and identify phenomena that provide evidence of the nature of light (<i>e.g., evidence provided by viewing the passage of light through dusty air or cloudy water</i>) 	1	2	3	4

Outcome #2- Investigate the transmission of light, and describe its behaviour using a geometric ray model

Essential Outcomes (Ideas I must understand)	My Understanding			
<ul style="list-style-type: none"> investigate how light is reflected, transmitted and absorbed by different materials; and describe differences in the optical properties of various materials (<i>e.g., compare light absorption of different materials; identify materials that transmit light; distinguish between clear and translucent materials; identify materials that will reflect a beam of light as a coherent beam</i>) 	1	2	3	4
<ul style="list-style-type: none"> measure and predict angles of reflection 	1	2	3	4
<ul style="list-style-type: none"> investigate, measure and describe the refraction of light through different materials (<i>e.g., measure differences in light refraction through pure water, salt water and different oils</i>) 	1	2	3	4
<ul style="list-style-type: none"> investigate materials used in optical technologies; and predict the effects of changes in their design, alignment or composition 	1	2	3	4

Outcome #3- Investigate and explain the science of image formation and vision, and interpret related technologies

Important Outcomes (Ideas that are important to know and be able to do)	My Understanding			
<ul style="list-style-type: none"> demonstrate the formation of real images, using a double convex lens, and predict the effects of changes in the lens position on the size and location of images (<i>e.g., demonstrate a method to produce a magnified or reduced image by altering the placement of one or more lenses</i>) 	1	2	3	4
<ul style="list-style-type: none"> demonstrate and explain the use of microscopes; and describe, in general terms, the function of eyeglasses, binoculars and telescopes 	1	2	3	4
<ul style="list-style-type: none"> explain how objects are seen by the eye, and compare eyes with cameras (<i>e.g., compare focusing mechanisms; compare the automatic functions of the eye with functions in an automatic camera</i>) 	1	2	3	4
<ul style="list-style-type: none"> compare the function and design of the mammalian eye with that of other vertebrates and invertebrates (<i>e.g., amphibians; fish; squid; shellfish; insects, such as the housefly</i>) 	1	2	3	4
<ul style="list-style-type: none"> investigate and describe the development of new technologies to enhance human vision (<i>e.g., laser surgery on eyes, development of technologies to extend night vision</i>) 	1	2	3	4
<ul style="list-style-type: none"> investigate and interpret emerging technologies for storing and transmitting images in digital form (<i>e.g., digital cameras, infrared imaging, remote imaging technologies</i>) 	1	2	3	4

Part A: What is light?

Light is a form of **energy** that allows us to see. Sources of light (where it comes from) can be natural or artificial. The sun is a **natural light source** and a light bulb is an **artificial light source**.

The basic properties (characteristics) of light are:

- It is a form of energy
- it travels in straight lines
- It can be reflected
- It can be bent

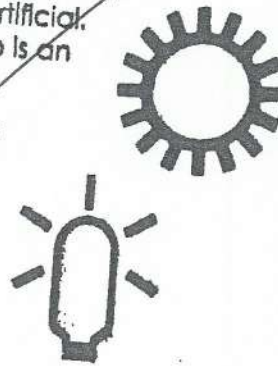

Brainstorm!

1. Before you start working through this unit, quickly write down all of the things you know about how light behaves. Think about interesting things you have seen light do or ways that you have played with light.

2. Write two questions about light that you think will be answered in this unit or you would like to know the answers to.

Did you know?

We often think of hurtful things when we hear the word **radiation**, but it is actually a scientific word that describes how light moves away from the sun. The sun creates light and the light **radiates** from the sun and the light rays spread out in all directions like the spokes in a bike wheel.

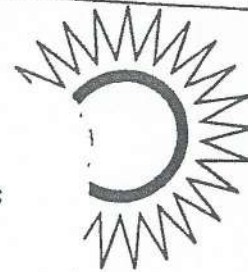

Handwritten text at the top of the page, possibly a title or introductory sentence.

Handwritten text in the middle section of the page.

Handwritten text in the lower middle section of the page.

Handwritten text in the lower section of the page.

Handwritten text at the bottom of the page.

Part B: What did people in the past think about light?

Pythagorus

In ancient Greece, a mathematician named Pythagorus developed a theory about light beams. He believed that light was made up of straight beams that came from a person's eyes and "lit up" the things they looked at. The obvious problem with his theory was that, if it were true, people would be able to see in the dark. Even though the theory was obviously not correct, people accepted it (believed it was true) for many years.



Euclid

Euclid, another scientist from ancient Greece, also believed that light travelled in straight lines. He used that knowledge to prove that the angle that a beam of light hit a mirror at was exactly the same as the angle of the reflected beam of light.

al-Haytham

In the year 1000, al-Haytham, an Arab scientist came up with a theory of how vision (eyesight) worked. Opposite to Pythagorus and Euclid, he believed that light bounced off objects and travelled towards our eyes and that is what made us able to see. Although he tried very hard to discover how light was responsible for making rainbows, he never came up with the answer.

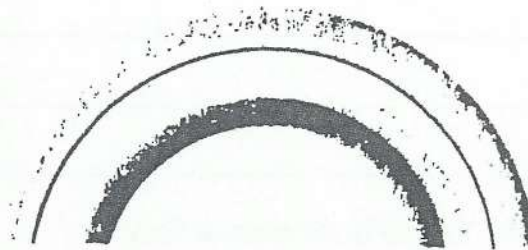

Rene Descartes

Rene Descartes was a French "thinker" who believed that rainbows were made up of sunlight that had been changed somehow so that it shined with different colours.

Newton

Sir Isaac Newton, an English scientist, conducted an experiment where he shined a beam of light through a prism (a piece of glass with triangular-cut sides). When the white light beam passed through the prism, it split into different colours. When another prism was put in front of the coloured light, it combined to form the white light beam again. This discovery led to theories of light that are still believed by scientists today.

Use the information on the previous pages to help you answer the following questions:

1. What part of Pythagorus's theory was obviously wrong? Why?

2. What part of the theories of Pythagorus and Euclid do present-day scientists agree with?

3. Why do you think people were willing to stop believing the theory that Pythagorus had come up with and start believing al-Haytham's theory?

4. Was Rene Descartes close to the truth about light?

5. What did Newton do that helped future scientists begin to understand that white light is actually made up of rays of different coloured light?

Did you know?

A rainbow is created when sunlight shines through drops of water in the air and the light is bent so much that it splits into its different-coloured rays. Red is always on the outside of the arc because those rays are the longest and lowest in energy. Violet is always on the inside of the arc because those rays are the shortest and most energetic.



Part C: Electromagnetic Spectrum

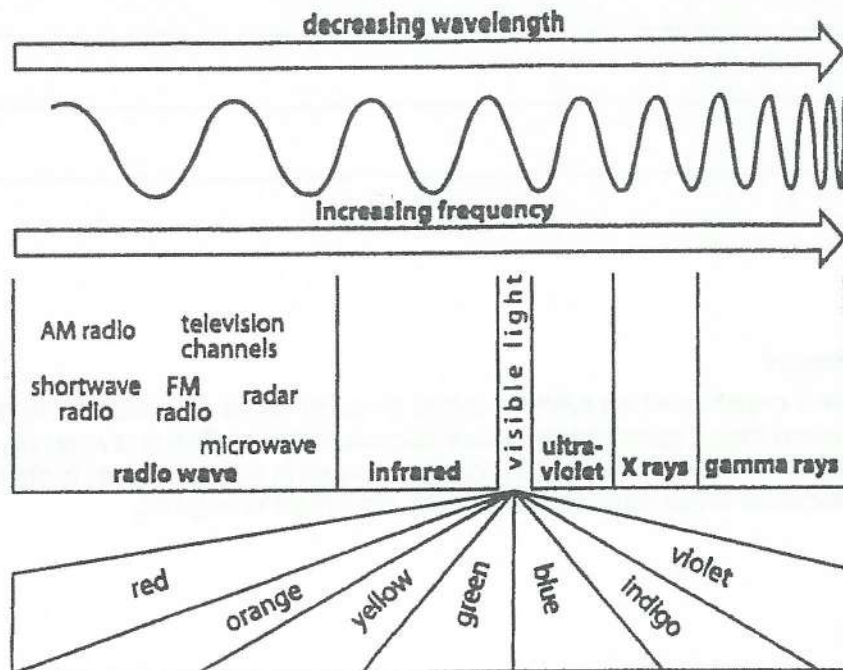

The Ray Model of Light

Scientists today believe that light travels in straight lines (rays) out in all directions from the light source. Radiation is when light moves out in all directions like the spokes of a wheel.

The Composition of Light

White light is the light we see around us but it is actually made up of rays of different lengths and colours. The colours of the rainbow—red, orange, yellow, green, blue, indigo and violet, are all combined to make white light.

Refraction

When a ray of light shines through two materials of different density, it is refracted (the ray of light is bent). This usually happens because the speed of light slows when it passes from a less dense material to one that is more dense. This only works when light can shine through both materials.

Reflection

Reflection is when light is cast (bounced) back from a surface. Reflection is what allows us to see the things in our world—from our image in a mirror to words on a piece of paper.

Absorption

Absorption is when surfaces "soak up" light and usually change it to a different kind of energy like heat. Think of something that doesn't reflect light but gets very warm when light is shined on it.

Use words from the definition boxes on the previous page to fill in the blanks in the following sentences in a way that makes sense.

- When you look in a mirror, you see your _____ because the light is _____ back from the _____ of the mirror.
- The light you see around you is called _____ light, but it is actually made up of _____ of different _____ and _____.
- When a ray of light shines through one material and then another, it is _____ if one material is more _____ than the other.
- When light shines from the sun, it travels in _____ lines called _____ and moves out in all _____ like the _____ of a wheel.
- Shadows are formed when solid objects are held in front of a light source because light travels in _____ lines and can't bend around solid objects.
- Dark, rough surfaces usually "soak up" the light through a process called _____.
- What do we currently believe about the nature of light?

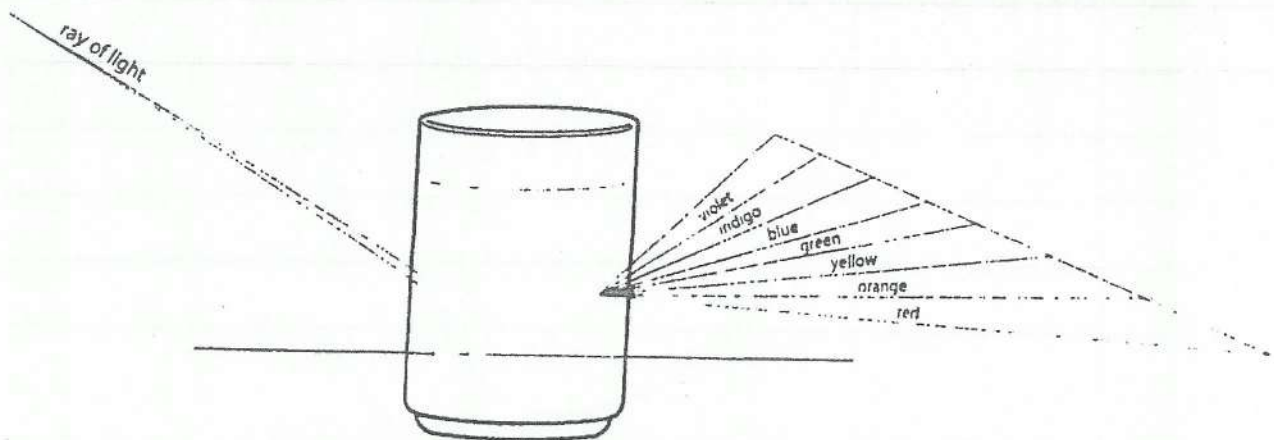

Investigate

Playing with Light

Consider: How does water affect rays of light?

Hypothesis: (check the one you agree with)

- when light shines through water it bends
- light can shine straight through water

Materials:

- one clear cup or glass
- water
- a pencil

Procedure: (record information in the box)

1. Place the pencil in the cup (let it lean against the side).
2. Move down so you can look directly in the side of the cup. Record what you see (use pictures and words).
3. Fill the cup half full of water.
4. Move down so you can look directly in the side of the cup again. Record what you see (use pictures and words).

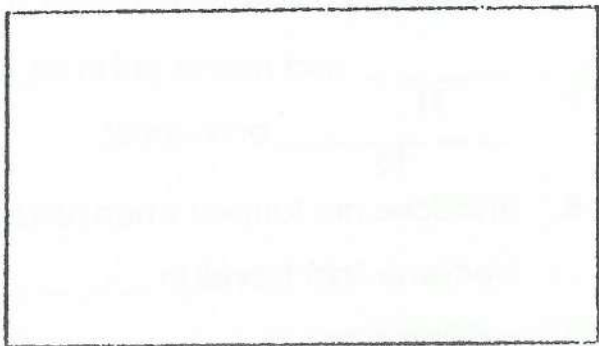

Analysis/Conclusion:

1. Did the light travel in a straight line through the air and the water? How do you know?

2. Now, answer the original question using evidence/examples from your investigation OR prove why your hypothesis was correct.

Part D: Interactions of Light

Transparent

Transparent materials, often called "see through," transmit light. This means that rays of light can travel right through them.

Translucent

Translucent materials let some, but not all, light travel through them. Shapes can be seen on the other side of translucent materials, but the actual images are blurry.

Opaque

Opaque materials don't let any light travel through them. They absorb or reflect light so it bounces back and a shadow is cast on the other side of the material.

Write the word **transparent**, **translucent** or **opaque** to describe how clearly we can see through each of these materials.

1. _____ A solid wood door
2. _____ A regular window pane
3. _____ A frosted window pane
4. _____ A piece of Saran Wrap
5. _____ A pencil
6. _____ A white piece of paper
7. _____ A piece of cardboard
8. _____ Water

Hint: If you aren't sure, try looking through each of these things when there is bright light on the other side. How clearly can you see through each one?

Sight

Light allows us to see objects because light reflects off objects in our surroundings and bounces back into our eyes.

Luminous

Objects that produce light, either naturally or artificially.

Non-luminous

Objects that do not produce light.

Use the information you have learned so far to help you analyze this picture and then fill in the blanks in the passage below.

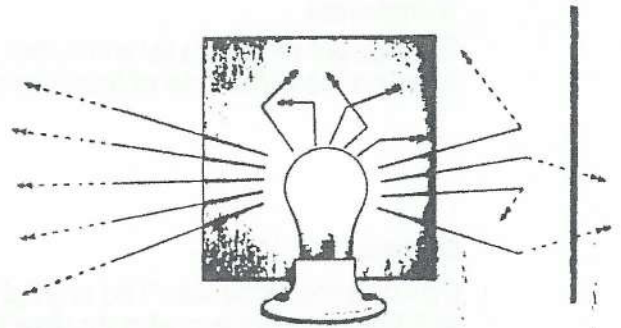

Our sense of _____¹ allows us to see the picture. The light bulb is a _____² object that gives off light. The panels around the light bulb are _____³ because they don't make their own light. The left panel is obviously _____⁴ because light rays travel through it and stay _____⁵. The right panel is obviously _____⁶ because not all of the light rays are shining through and the ones that do go through have been _____⁷ and are now shining out at a different angle. This is called _____⁸. The back panel is obviously _____⁹ because no light rays are shining through, they are being _____¹⁰ back away from the panel.

Check your answers! These are the words that are missing from the passage above.

non-luminous	opaque	refraction	transparent	straight
sight	translucent	luminous	bent	reflected

Part E: How does reflection work?

Reflection

Reflection is a process where light hits a surface and then bounces back off that surface. How the reflection process works depends on how smooth the surface is. Seeing our image in a mirror and reading the words on this page both involve the process of reflection. We see different things because the two surfaces—glass and paper—are very different. Glass is very smooth and reflects light rays straight back. Paper (when you look at it with a microscope) is very rough, so the light rays bounce off in all directions. When light bounces straight back, you see a "copy" of the image in front of it. When light bounces off in different directions, you see what is on the surface (e.g., writing on a page).

In the reflection process, rays of light are given different names depending on the "job" they do, for example:

Incident (in-si-dent) Ray

The ray of light that first hits the surface.

Reflected Ray

The ray of light that bounces off the surface. The straight path (line) that each ray of light travels along is compared to the "normal" line and then described as an angle.

Normal Line

A straight, perpendicular line (90 degrees from the surface) that extends (goes out) from where the incident ray hit the surface.

Angle of Incidence

The difference between the line that the incident ray followed and the normal line (called an angle because it's measured in degrees).

Angle of Reflection

The difference between the line that the reflected ray followed and the normal line.

Study the diagram below and then answer the questions on the next page.

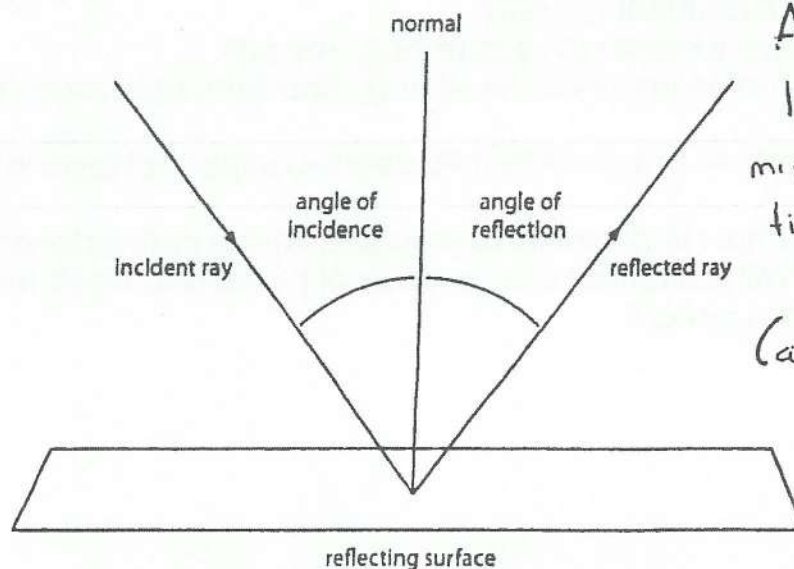

Activity - Using the laser pointer and mirrors see how many times you can reflect the light.
(ask for materials)

Use the information on the previous page to help you answer the following questions. Label questions that are **True** with a **T** and questions that are **False** with an **F**.

1. ___ The ray of light that bounces off a surface is called the reflected ray.
2. ___ The ray of light that bounces off a surface is called the incident ray.
3. ___ The ray of light that first hits a surface is called the reflected ray.
4. ___ The ray of light that first hits a surface is called the incident ray.
5. ___ The normal line is a straight, perpendicular line that extends from where the incident line hits the surface.
6. ___ The angle of incidence is the difference between the path of the reflected ray and the path of the incident ray.
7. ___ The angle of incidence is the difference between the path of the incident ray and the normal line.
8. ___ The angle of reflection is the difference between the path of the reflected ray and the normal line.
9. ___ The angle of reflection is the difference between the path of the reflected ray and the incident line.

Consider the following question:

Is the angle of incidence always the same as the angle of reflection?

Using the planner on the following page, design an experiment to find the answer to the question above. Consider the following things:

- What is your hypothesis (guess)?
- What reflective surface will you use (e.g., mirror)?
- What other materials will you need (e.g., flashlight, dark room, measuring devices)?
- Do you know how to calculate a 90 degree angle and draw a "normal" line?
- Do you know how to measure your angles using a protractor or will you need help? Will you reflect onto a piece of paper and trace the path of the light with a pencil?

Title:

Question to Consider:

Hypothesis: (my guess)

Materials:

-
-
-
-
-

Procedure: (record information on the lines)

1. _____

2. _____

3. _____

4. _____

My Observations: (what happened)

Analysis/Conclusion:

1. My answer to the original question using evidence/examples from my investigation OR my proof that my hypothesis was correct.

Part F: How does refraction work?

Refraction

Refraction is when light bends because it is moving from one type of material to another (usually transparent). "Bent" light still travels in straight lines. It's just the direction of the line that changes (think back to what you learned before about angles). Light bends because the speed at which it is moving changes when it passes through materials that have different densities (a different number of particles packed into them). The more dense a material is, the slower light passes through it. When the light bends, it makes objects look as if they are in a different position.

Think back to the experiment you conducted earlier in this unit, did the water bend the light? Did the pencil look as if it were in a different position in the water?

Study the diagram below and then answer the questions.

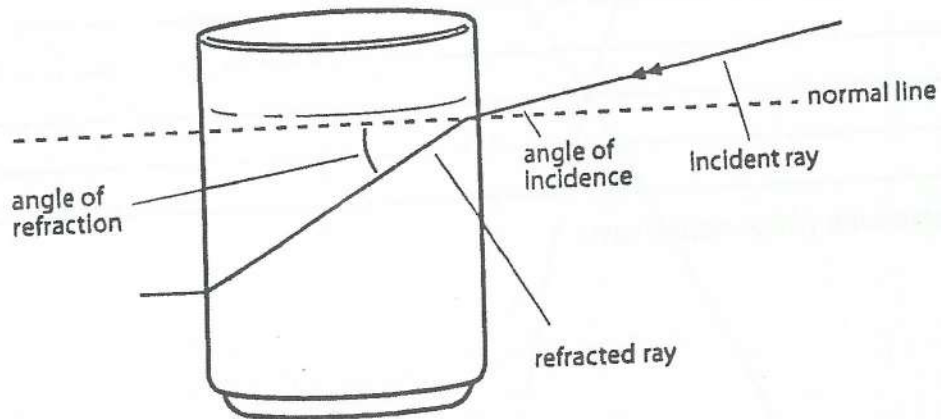

1. Is water more dense than air? How do you know?

2. Are the angle of incidence and the angle of refraction always the same? Explain.

Refraction

Consider: How does the density of a liquid affect the way light refracts?

Important Information: The more particles packed into a substance, the denser it is.

Hypothesis: (check the one you agree with)

- the greater the density, the more obvious the refraction
- the lower the density, the more obvious the refraction

Materials:

- four clear cups or glasses
- water, water mixed with salt, cooking oil, translucent shampoo
- four pencils

Procedure: (record information in the boxes)

1. Fill each cup with one of the liquids.
2. Place a pencil in each of the filled cups.
3. Record your observations (use pictures and words).

Water	Salt Water	Cooking Oil	Shampoo

Analysis/Conclusion:

1. Answer the original question using evidence/examples from your investigation OR prove why your hypothesis was correct.

2. Go back to question 2 on page 13. Check your answer.

Use what you have learned to correctly organize this information in the chart below.

Type of Behaviour:

- Absorption
- Reflection
- Refraction

What happens to the light that hits the surface?

- Bounces off the surface and travels back
- Disappears/changes into another kind of energy like heat
- Travels through the surface and out in a new direction

What is the surface usually like to make that happen?

- Different, transparent material
- Smooth, shiny surface
- Rough, dark, opaque surface

**Type of
Behaviour**

**What happens to the light when it
hits the surface?**

**What is the surface usually like to
make that happen?**

Did you know?

Sunsets are red, orange and yellow because those are the longest rays of light. As the sun disappears below the horizon, it gets further away from us so more of the particles (dust, etc.) in our atmosphere get in the way of the light. The shortest rays of light get bounced away, so those colours "disappear" before the light gets to us and all we see are the longer rays (red, orange, yellow).

Part G: How do lenses help us control light?

Lens

A lens is a piece of glass or other transparent material that either brings rays of light together or spreads them apart.

Concave Lens

A concave lens is a piece of transparent material that is thinner in the middle than it is at the edges. Looking into a concave lens is like looking into a dish.

When light rays shine through concave lenses, the rays spread out.

When you look at an image through a concave lens, the image looks smaller and closer.

Convex Lens

A convex lens is a piece of transparent material that is thicker in the middle than at the edges. Looking into a convex lens is like looking through an upside-down dish.

When light rays shine through convex lenses, the rays are brought closer together.

When you look at an image through a convex lens, the image looks larger and further away.

Single Lens

A single lens has only one side that is curved (convex or concave) and the other side is flat.

Double Lens

A double lens has two sides that are curved (convex or concave) so it doubles the effect of the lens.

Use the information above to help you complete the sentences below.

1. When you look through a magnifying glass, the objects you are looking at seem larger and you can see them in more detail. The lenses in a magnifying glass are _____.
2. A telescope takes a view that is far away and brings the light rays together so the image seems closer and is easier to see. The lens in a telescope is _____.
3. A microscope has lenses of different powers that take an image and spread the light rays apart so the image looks larger and you can see it in more detail. The lenses in a microscope are _____.

Use what you have learned so far to help you answer the following questions:

1. Are telescopes and microscopes "opposite" technology? Explain your answer.

2. What kinds of things can magnifying glasses be used for?

People who wear glasses are either near-sighted or far-sighted. People who are near-sighted can see things that are close to them but have trouble seeing things that are far away. People who are far-sighted can see things that are far away but have trouble seeing things that are close to them.

3. What kind of lenses should people who are near-sighted have in their glasses? Why?

4. What kind of lenses should people who are far-sighted have in their glasses? Why?

Playing with Lenses

Consider: What happens to a beam of light when it passes through a concave and convex lens?

Hypothesis: (check the one you agree with)

- the concave lens will spread the light rays apart and the convex lens will blend them back together
- the convex lens will spread the light rays apart and the concave lens will blend them back together

Materials:

- concave lens
- convex lens
- flashlight or other source that sends out a beam of light
- darkened room

Procedure: (record observations in the box)

1. Shine the light through one of the lenses.
2. Shine the light through the other lens.
3. Position the lenses in a way that lets you shine the light through one and then the other.

Analysis/Conclusion:

1. Now, answer the original question using evidence/examples from your investigation OR prove why your hypothesis was correct.

Optional Extension

Investigate to find out what happens when you shine light through double lenses. Record your findings.

Part H: How do mirrors help us control light?

Mirrors

A polished surface of glass or metal that clearly reflects an image. Light rays bounce straight back from flat mirrors.

Concave Mirror

A concave mirror is thinner in the middle than it is at the edges. Looking into a concave mirror is like looking into a dish.

When light rays bounce off a concave mirror, the rays are brought closer together. When you look at an image reflected by a concave mirror, the image looks bigger (magnified).

Convex Mirror

A convex mirror is thicker in the middle than at the edges. Looking into a convex mirror is like looking at an upside-down dish.

When light rays bounce off a convex mirror, the rays spread out. When you look at an image reflected by a convex mirror, the image looks smaller but the field of view is greater.

Use the information above to answer the questions below.

1. Are mirrors and lenses "opposite" technology? Explain your answer.

The side mirrors on cars usually have a warning that "objects may be closer than they appear." In other words, the reflection is what makes the object look smaller so it seems farther away and more of the area around the car can be seen.

2. What kind of mirrors are used in car side mirrors? How do you know?

3. How does using these types of mirrors in car side mirrors make it safer for drivers?

4. What kinds of mirrors do you think are used in far corners of stores so that staff can watch people closely and catch thieves?

Part I: What do we know about light today?

What is a telescope and how does one work?

Telescopes consist of many basic parts. Look at the diagram below and read the labels, then use what you have learned to complete the passage below.

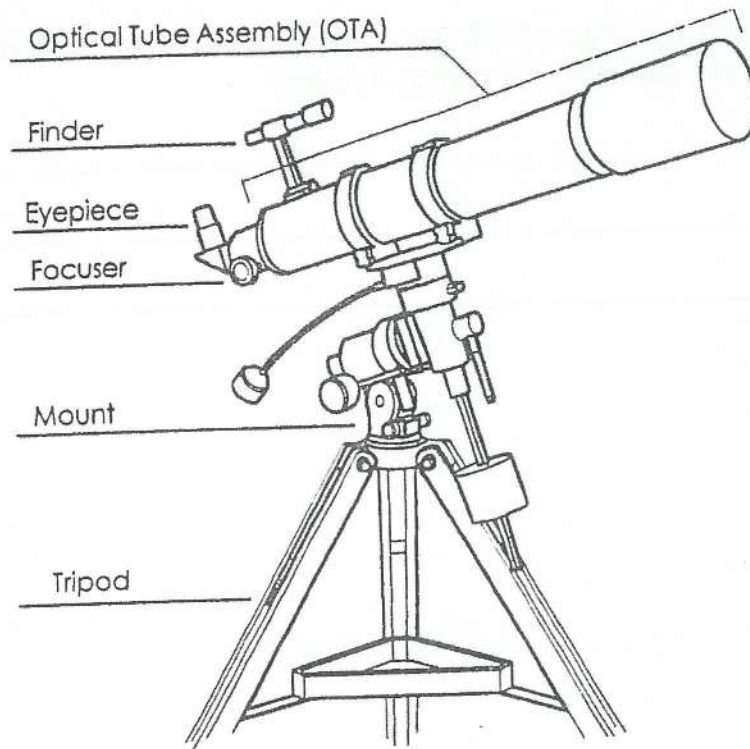

The Parts of a Telescope

Use each of the diagram labels to fill the blanks in the passage below.

The _____₁ is the main "long part" of a telescope that contains mirrors and/or objective lenses for magnification. The _____₂ is the small end of the telescope that you look through. The _____₃ lets a person see more clearly by moving the mirrors and/or lenses up and down in the tube. A _____₄ is a mini-telescope that is mounted on the outside of the tube to help in locating objects in a larger area before looking at them closely. The _____₅ holds a telescope in position on the _____₆.

What are the two main types of telescopes?

The two main types of telescopes are the refracting telescope and the reflecting telescope. A refracting telescope uses only lenses, but a reflecting telescope uses a combination of lenses and mirrors.

Study the diagrams below. Look closely at the arrows that show the path of light through each telescope and then answer the questions on the next page.

Refracting Telescope

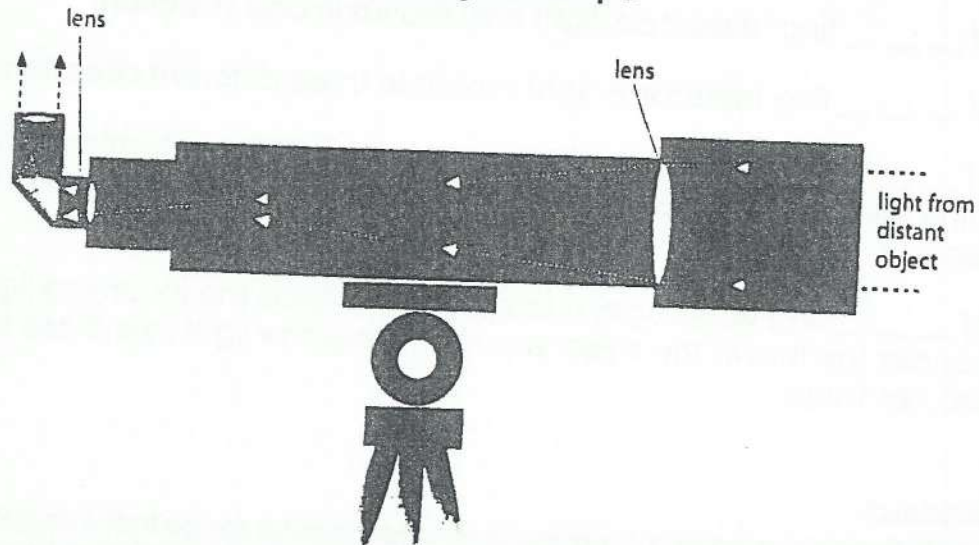

Reflecting Telescope

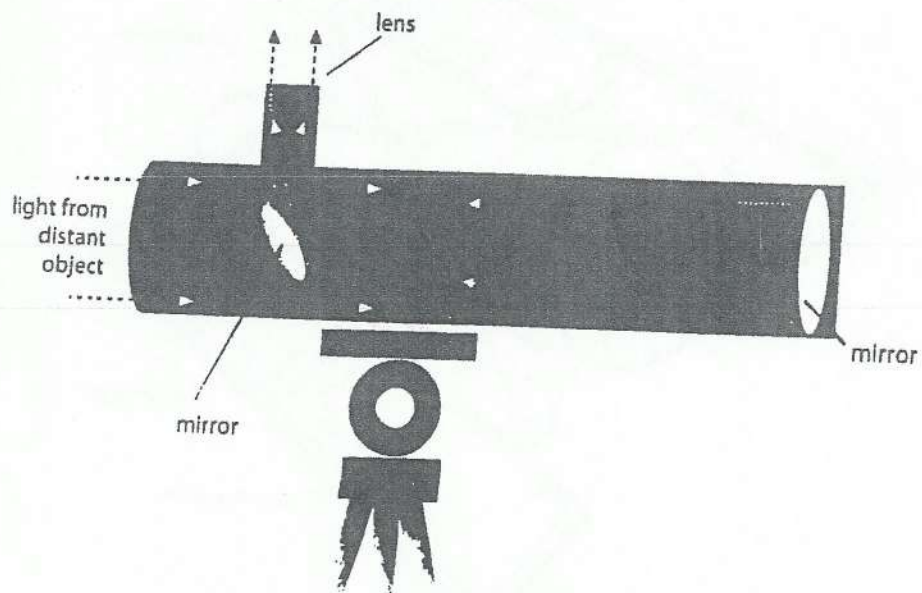

Write the word **refracting** or **reflecting** in the blanks in each of the following sentences to make them correct.

1. A ref _____ ting telescope uses a curved, circular mirror that collects rays of light.
2. A ref _____ ting telescope has two lenses—one on each end of a long tube.
3. In a ref _____ ting telescope, light only moves in one direction.
4. In a ref _____ ting telescope, light moves in three different directions.
5. In a ref _____ ting telescope, a large lens catches the incoming light and brings the light's rays close together and focuses them on the lens in the eyepiece.
6. In a ref _____ ting telescope, a large mirror reflects the incoming light to a mirror under the lens in the eyepiece that brings the light rays close together and focuses them.

Did you know?

The Hubble Space Telescope is a moving observatory in outer space that was built for the benefit of the international astronomical community by the European Space Agency (ESA) and the National Aeronautics and Space Administration (NASA).

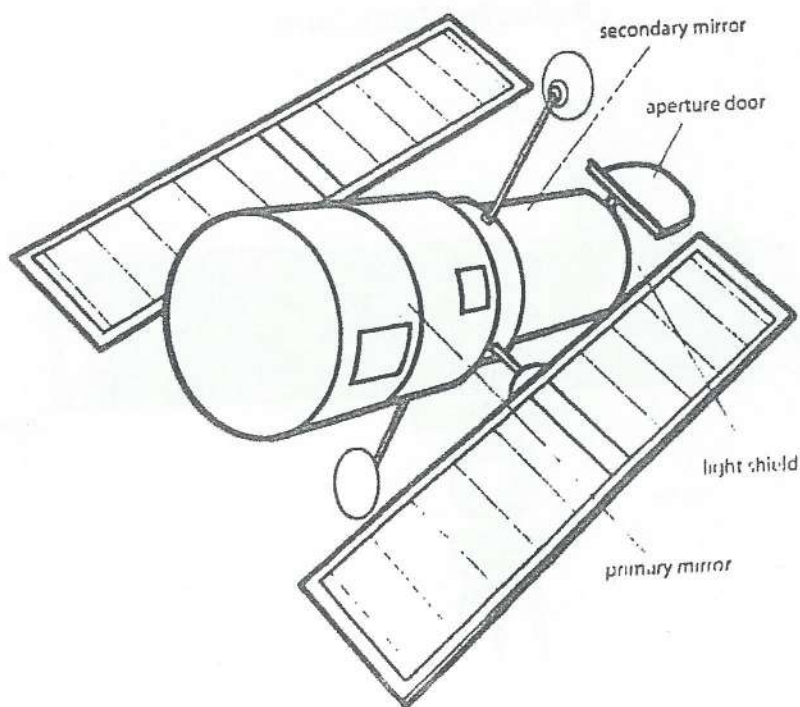

What is a microscope and how does one work?

A microscope is a tool that extends your sense of sight. This means that it lets you see more than you could see without it. Unlike a telescope that lets you see things far in the distance, a microscope is used to look more closely at things—so close that you can often see inside them.

Most schools use **compound light microscopes**. Any microscope that has two or more lenses is called a **compound microscope**. The word **light** is added to the name because a bright light is used to help you see better.

The Parts of a Compound Light Microscope

The top of the microscope (where you look into it) is called the **eyepiece**. The eyepiece has a lens in it that magnifies what you see. It sits at the top of a **tube** that connects it to the revolving nose piece. The **revolving nose piece** has three **objective lenses** sticking out of it. It is called a revolving nose piece because it can be turned around and around so people can look through the different lenses. Each of the objective lenses is a different strength (each magnifies differently).

All of these pieces—the eyepiece, the tube, the revolving nose piece and the objective lenses, are all held up by the microscope's **arm**. The arm is the long, curved piece that acts as the microscope's handle. On the arm are two round adjustment knobs. The larger one is called the **coarse-adjustment knob** and it moves the stage up and down to help bring the object into focus. The smaller one is called the **fine-adjustment knob** and it brings the object into sharp focus under the lens.

At the bottom of the arm is a flat **stage** that acts as a table for the object that is being examined (looked at). Just underneath the stage is a dial that can be turned to change the amount of light shining up at the object. This dial is called the **diaphragm (di-a-gram)**. Under the diaphragm is a round bulb called the **light source**. It shines up through the object being examined to help you see it better. Below the light source is the microscope's **base**—the flat, heavy plate that lets it sit firmly on a flat surface.

Parts of a Compound Light Microscope

Use the **bolded words** from the passage called *The Parts of a Compound Light Microscope* to label the diagram below. All of the bolded words must be used and each should be used only once

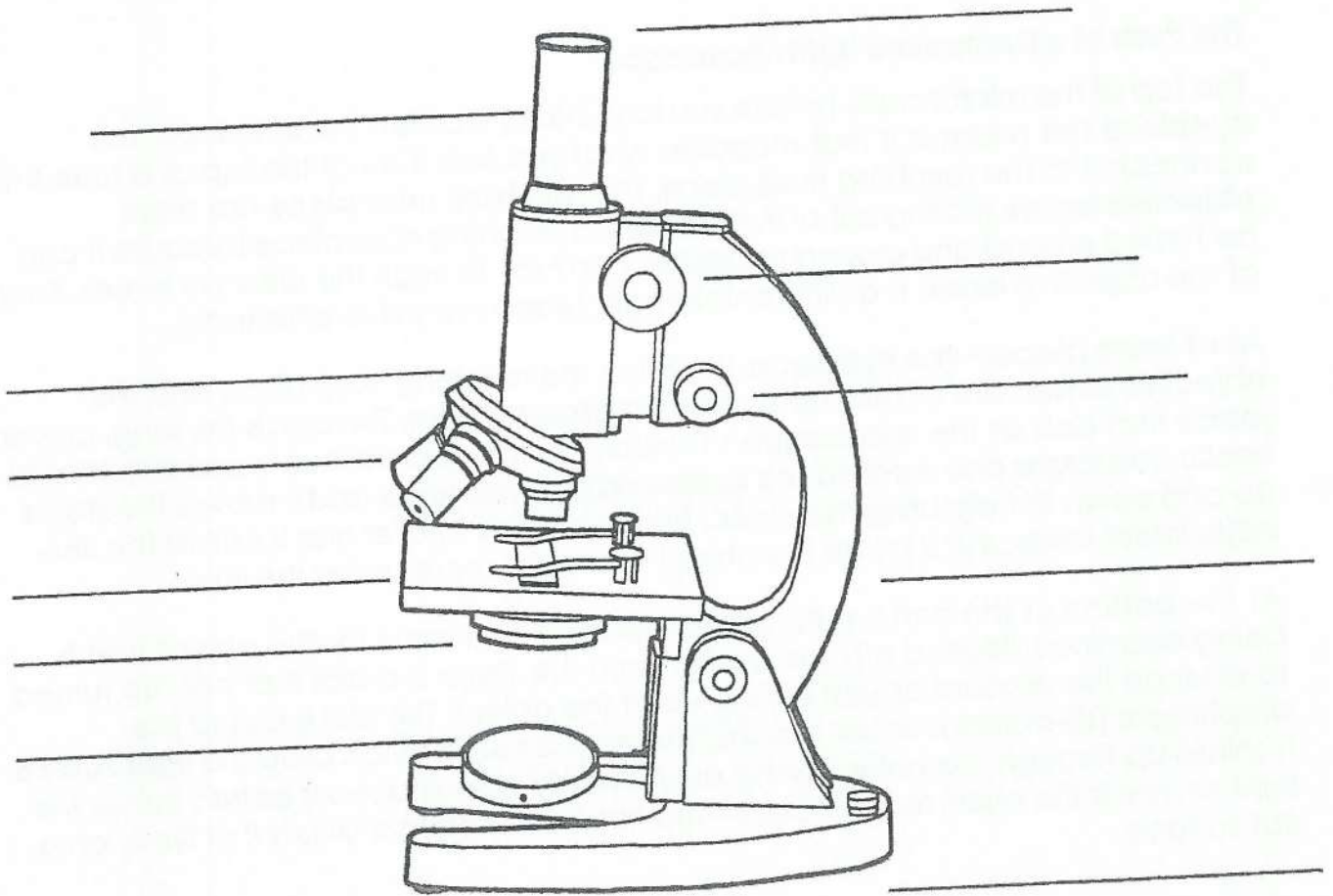

- ask to see our microscope and
slides to check out ... dead flies ...
hair ... plant roots ...

Part J: What is optical technology?

Optical Technology

Optical technology is when we use light and control the way it behaves to help us do work. Many modern machines, such as microscopes, use optical technology.

Lasers

The word laser is an acronym and it stands for **L**ight **A**mplification by **S**timulated **E**mission of **R**adiation. In other words, lasers work by amplifying (making stronger or purer) rays of light.

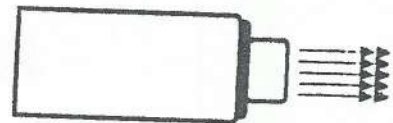

You learned earlier in this unit that light is made up of coloured rays that are all different lengths. This "regular" light is called **Incoherent light** because its waves are all different sizes and travel out in all directions sometimes bumping into one another. A laser is a kind of **coherent** light because it controls light rays so they all shine together in one direction and are all the same long length, this is why most laser beams are red (the longest ray).

Fibre Optics

Fibre optics is another optical technology that involves creating special tubes for light to travel along. The tubes are usually very small and they often look like fishing line. The tubes are made of a thin circle of glass covered in plastic. When light shines on the tube, it reflects all the way along but doesn't escape out the sides. The only place you can see the light is at the end of the tiny tube. Fibre optic cables can carry light a long distance and are often used to carry information that is communicated through light signals.

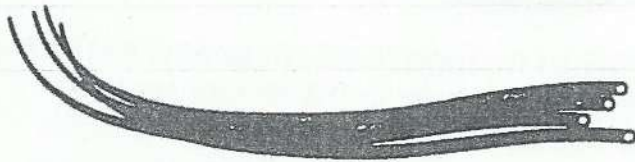

Independent Research
Learn more about laser or fibre optic technology and how each helps people do work. Look for books in the library, search on the Internet or ask your science teacher!

Part K: How are our eyes like film cameras?

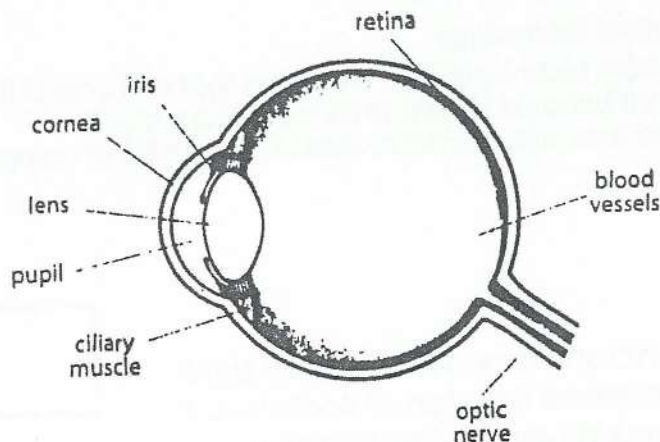

The iris is the coloured part of the eye. The black part in the middle is the pupil. The pupil is an opening controlled by a circle of muscles that open and close to adjust the amount of light passing into the eye. When the light goes into the eye, it passes through a convex lens that brings the light rays together and focuses them. The focused light hits the retina at the back of the eye. The retina is like a movie screen that is attached to the brain by the optic nerve. The image that is projected onto the retina is actually an upside-down version of what the eye is looking at. The brain is able to figure out what the right-side up image looks like, so we aren't even aware that the image is upside down.

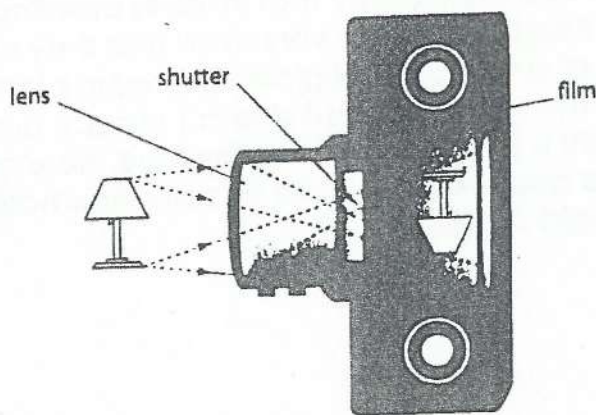

The lens of a camera is on the front. Light shines through the convex lens that brings the rays together. The light then passes through the hole in the diaphragm (di-a-gram) that opens and closes to let light in. The image is projected onto the camera film. The image is upside-down but, with photographs, all the developer needs to do is flip it the other way to see it properly!

Did you know?

Different kinds of optical technology use lenses in a way that flips images upside down. You can check this by drawing the letter "a" on a piece of paper and looking at it under a microscope.

Goal • Calculate the cost of electricity.

Think About It

Have you ever been told to turn off the lights in your room when you leave? This is because energy costs money. We have to pay for the gasoline needed to drive a car, and for the electricity used by our lights and appliances.

The cost of electricity varies. In rural areas, electricity often costs more than it does in cities because the electric companies have to use longer wires to service fewer people. Businesses, industries, and homes are charged different rates. How much do you think it costs to use electricity? Complete this worksheet to find out.

What to Do

Answer the following questions in the space provided. Assume that electricity costs $8\text{¢}/\text{kW}\cdot\text{h}$. This means that if a 1000 W appliance is left on for 1 h, it uses 8¢ worth of electricity.

$$\begin{aligned}\text{Cost} &= \text{number of kilowatts} \times \text{number of hours} \times 8\text{¢} \\ &= \text{number of watts} \div 1000 \times \text{number of hours} \times 8\text{¢}\end{aligned}$$

1. What is the cost of electricity in each situation? Show your work.

(a) A 100 W light bulb is left on from 10:00 at night to 7:00 the next morning.

(b) A turkey takes 3 h to cook in a 1500 W oven.

(c) You watch a 500 W television set for 7 h.

Going Further

- Lee's family has a summer cottage that they usually close up for the winter. One year, they closed up the cottage on October 8. When they returned the next year, on May 22, they discovered that they had left a 1 kW heater on. Assuming that the heater ran about half the time, approximately how much did this little mistake add to their electricity bill?

Goal • Classify various materials as transparent, opaque, or translucent, and describe the behaviour of light when it strikes different materials.

What to Do

Answer the following questions in the space provided or on a separate page.

1. What does a sharp shadow tell us about the way light travels?

2. Describe how light is affected by

(a) a transparent object _____

(b) an opaque object _____

(c) a translucent object _____

3. Why is frosted glass often used for bathroom windows instead of clear glass or a solid wall?

4. Complete the table below. In the second column, classify each material as transparent, opaque, or translucent. In the third column, state whether light is absorbed, reflected, transmitted, or scattered when it strikes the material. In the last two boxes of the first column, write your own examples.

Material	Classification	Behaviour of light
glass		
white clouds		
stained glass window		
aluminum foil		
fog		
cellophane		
cardboard		
wax paper		
black chalkboard		
mirror		
	transparent	
		scattered

4. Define the following terms:

- Incident Ray

- Reflected Ray

- Normal Line

- Angle of Incidence

- Angle of Reflection

5. Draw the diagram on page 189, that shows light reflecting of a mirror surface

Goal • Review your understanding of light rays.

What to Do

1. (a) Label the diagram below using the following terms: reflected ray, angle of reflection, angle of incidence, incident ray, normal line.

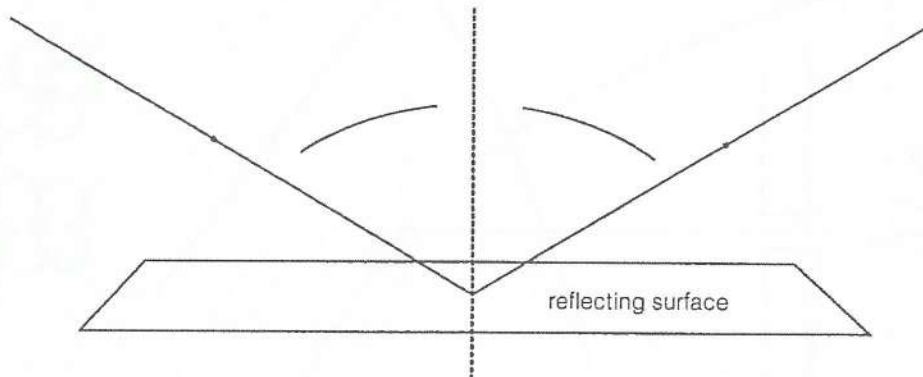

- (b) Measure the angles of incidence with your protractor. _____
- (c) Measure the angle of reflection with your protractor. _____
- (d) Compare the sizes of the angles of incidence and reflection.

2. Use the law of reflection to draw the path of the reflected ray from the mirror in the diagram below.

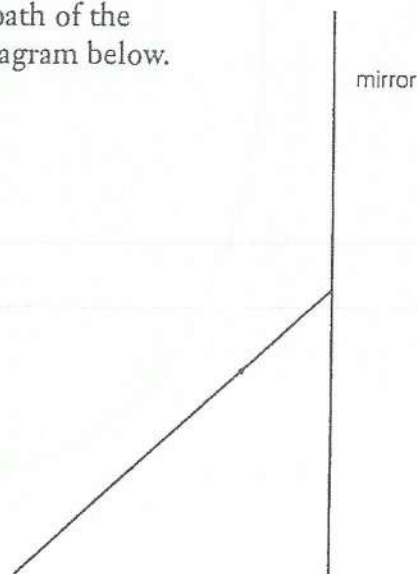

TOPIC 1
REINFORCEMENT

Ray Diagrams (continued)

BLM 3-5

3. The following diagram shows a light ray coming through an opening. It is directed at two mirrors and three flowers. Use the law of reflection, your ruler, and your protractor to draw the light ray as it bounces from one mirror to the next. Which of the three flowers will be hit by the light?

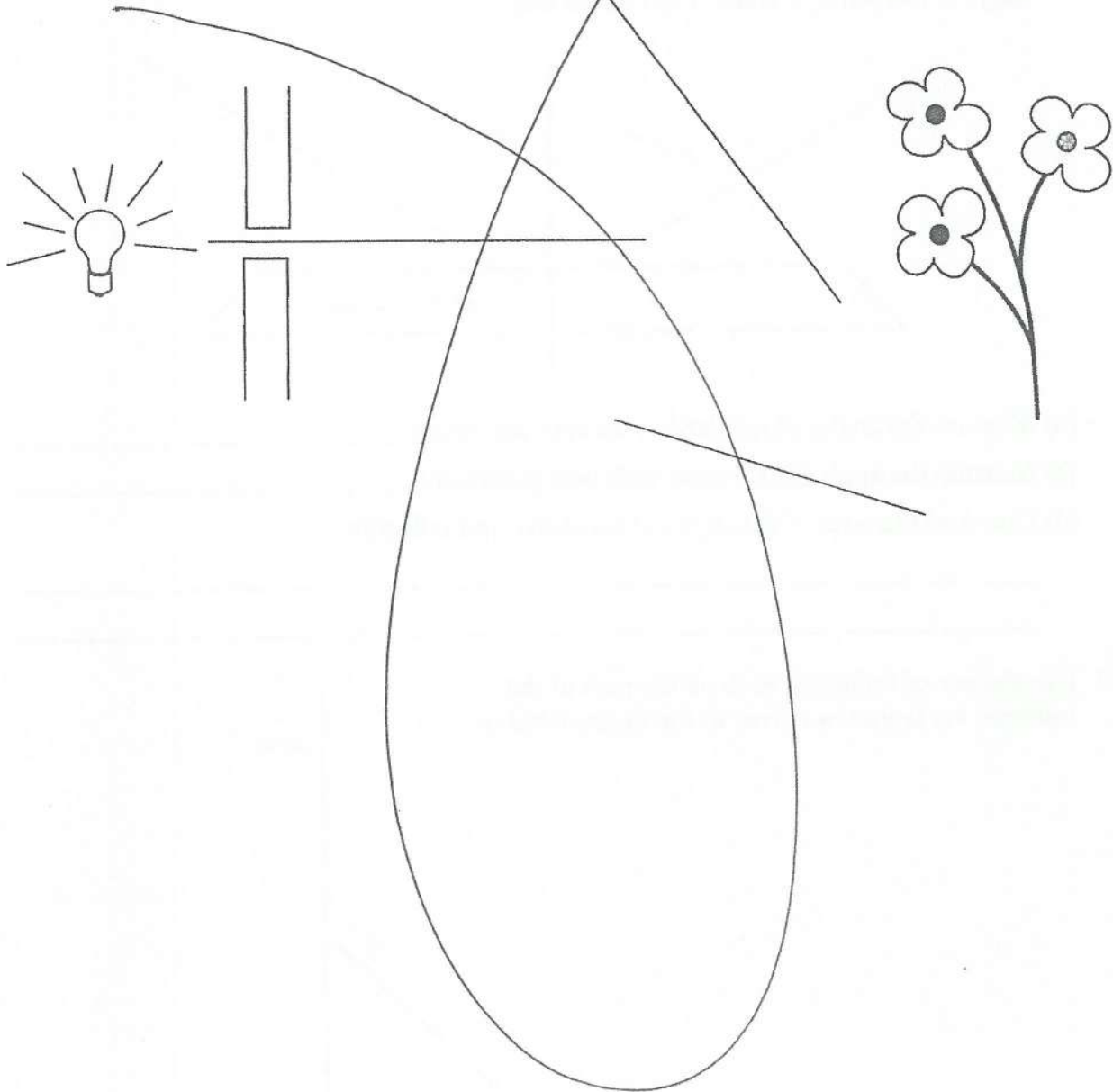

What You See Is What You Get

Goal • Reinforce your understanding of the principles of reflection.

What to Do

1. Use a ruler to draw the reflected images of the objects below.

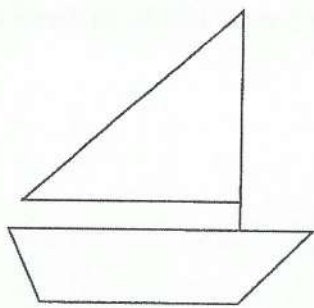
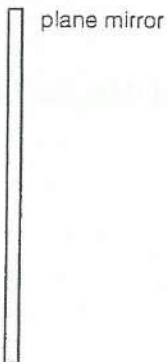
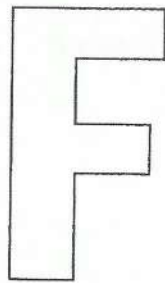

2. Were there any differences between the object and its image in the plane mirror? Describe any differences, with respect to

(a) size

(b) distance from the mirror

(c) orientation

Name: _____

Date: _____

Science Eight
Module Three
Light and Optical Systems
Investigation #3

1. Define refraction:
2. When referring to light travel, what does the "medium" refer to?
3. Why does light refract when moving from air into water? (Refer to density in your answer)
4. Look at figure 3.26 in your textbook. Explain why there is a difference between actual and apparent position.

Name: _____

Date: _____

5. Look at figure 3.27 in your textbook. Follow the ray of light as it moves from air – water – air. Describe how the ray changes directions throughout

6. In regards to the normal line, how does light travel in each of the following:

- From less dense to more dense

- From more dense to less dense

7. Define angle of refraction:

Goal • Review how light bends when it travels from one material to another.

Introduction

When light moves from one medium (such as air) to another (such as water), it bends. This is called *refraction*. The light bends because it changes speed when it moves between materials that have different densities.

What to Do

Answer each question in the space provided.

- The diagrams below illustrate refraction. In (a), for example, the light ray travels through the air and enters the glass. In (b), the light ray travels up from the water and enters the air. For each diagram, draw the normal line at the point of contact. Measure and label the angle of incidence and the angle of refraction. Then complete the sentences that follow from the choices in parentheses.

(a) air to glass



The angle in the air is _____ (*greater/less*) than the angle in the glass.

The light entering the glass bends _____ (*toward/away from*) the normal line.

(b) water to air

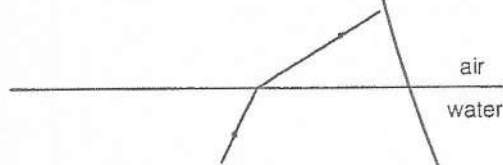

The angle in the air is _____ (*greater/less*) than the angle in the water.

The light entering the water bends _____ (*toward/away from*) the normal line.

TOPIC 3

SCIENCE INQUIRY

Refraction (continued)

BLM 3-10

(c) air to water

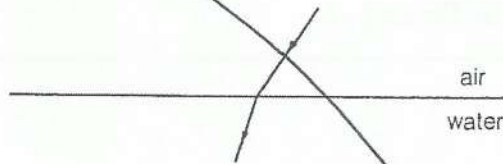

The angle in the air is _____ (*greater/less*) than the angle in the water.

The light entering the air bends _____ (*toward/away from*) the normal line.

(d) transparent plastic to air

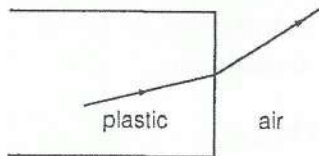

The angle in the air is _____ (*greater/less*) than the angle in the plastic.

The light entering the air bends _____ (*toward/away from*) the normal line.

2. Use the terms below to complete the sentences that follow. If necessary, you may use a term more than once.

greater than
less than

toward
away from

When light refracts, the angle in the air is always _____ the angle in the other substance. Light entering the other substances bends _____ the normal line.

Light leaving a substance and entering the air bends _____ the normal line.

Goal • Assess your understanding of concepts in Topics 1-3.

What to Do

Carefully read the instructions before answering each set of questions.

Fill in the Blanks

Use the terms below to complete the sentences that follow.

bioluminescence	fluorescence	opaque	scattering
chemiluminescence	incandescence	reflection	translucent
diffusion	phosphorescence	refraction	transparent

- _____ material reflects or absorbs all light that hits it.
- You can see an object clearly through _____ material.
- Some light comes through _____ material, but you cannot see an image clearly.
- The change in the direction of light when it bounces off a surface is called _____.
- The change in the direction of light as it enters a different substance is called _____.
- The type of light energy that is stored by certain particles for a period of time is called _____.
- The type of light that is produced when a material is heated is called _____.
- A special type of light that is produced by living organisms is called _____.

Multiple Choice

Circle the best answer.

- A unit of electrical energy is a

(a) watt	(c) kilowatt-hour
(b) kilowatt	(d) hour
- The glowing portion of an incandescent bulb is the

(a) filament	(c) socket
(b) glass	(d) base

Topics 1-3 Test (continued)

11. Which of the following is not found in a fluorescent bulb?
(a) electrode (c) vapour
(b) filament (d) phosphor coating
12. The light energy that is given off by light sticks comes from
(a) solar energy (c) chemical energy
(b) electrical energy (d) thermal energy
13. The ray of light that hits a surface is called the
(a) incident ray (c) reflected ray
(b) refracted ray (d) normal ray
14. A 60 watt light bulb and a 100 watt light bulb differ in
(a) colour (c) size of the base
(b) how long they last (d) intensity of the light they produce
15. A pencil in a glass of water can look bent at the surface because of
(a) refraction (c) warping
(b) reflection (d) drying

Short Answers

Answer each question in the space provided.

16. Light reflects off a mirror. Light reflects off the white surface of a ceiling or a wall. Why can you see images in a mirror but not in a ceiling or a wall?

17. What evidence shows that light travels in straight lines?

18. State the two laws of reflection.

19. Compare the advantages and disadvantages of using an incandescent light bulb and a fluorescent tube.

Diagrams

20. Draw a diagram that shows light bouncing off a mirror. Draw the normal line to the mirror. Label the angles of incidence and reflection.

21. Show the path of a light ray hitting the surface of a pond. The angle of incidence with the normal line is 30° . Then show the approximate path of the light ray as it travels down through the water.

22. Look at the diagram below. The cup is opaque, and it is filled with water. Draw a light ray that shows why you would not be able to see the coin if you were looking directly at it. Then add a light ray to show that you might be able to see the coin by looking at the surface of the water.

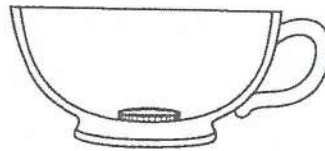

Problem Solving

23. Every night for 10 weeks in the summer, 20 10 W garden lights are lit for 3.5 h. What is the cost of the electricity, at a rate of 4¢/kW•h? Show your calculation.

5. Read page 210, and look at diagram 3.32B. Explain the following;

- Far-sightedness

- Near-sightedness

6. How do corrective lenses, such as glasses and contacts, change the path of light within an eye?

7. Define accommodation:

Name: _____

Date: _____

8. Why do people often need reading glasses as they age?

9. How does your pupil and iris change in response to changing light conditions?

10. Read "Seeing the Image" on page 217 of your text. Then, try the blind spot activity that follows.

Different Mirror Surfaces

Goal • Reinforce your understanding of the kinds of mirrors used for different purposes.

What to Do

Identify the type of mirror (plane, convex, or concave) used in each situation below. Write your answer on the line provided.

1. bathroom wall mirror

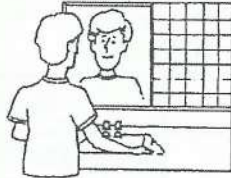

Purpose: to show your exact appearance

Type of mirror: _____

5. car headlights and flashlights

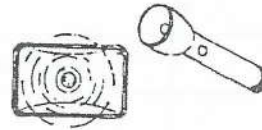

Purpose: to project a strong beam forward

Type of mirror: _____

2. store surveillance mirror

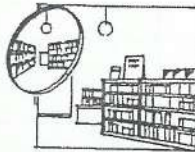

Purpose: to show a wide view

Type of mirror: _____

6. cosmetic mirror

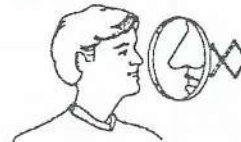

Purpose: to show a magnified view of parts of your face

Type of mirror: _____

3. one-way mirror



Purpose: to see into a brightly lit room; looks like a mirror to the people being observed

Type of mirror: _____

7. car mirror

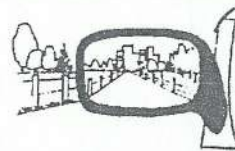

Purpose: to show a wide-angle view behind and beside the car

Type of mirror: _____

4. dental mirror



Purpose: to make the teeth visible and magnify them

Type of mirror: _____

8. reflecting ball at a dance



Purpose: to project portions of light hitting it in many different directions

Type of mirror: _____

Functions of an Eye and a Camera

Goal • Reinforce your knowledge of the functions of parts of an eye and parts of a camera.

What to Do

Complete the following table to compare an eye with a camera. Do not write anything in the shaded boxes. For help, review pages 211 and pages 216 to 218 of your textbook.

Eye		Camera	
Part	Function	Part	Function
		shutter	opens to take a picture
retina			catches the image
	clear covering over the eye	protective glass	lens cover protects the lens
iris		diaphragm	
		automatic brightness adjustment	opens and closes the diaphragm according to brightness of the subject
	focuses the image on the retina		
ciliary muscle		focussing ring	
		aperture	hole through which light enters the camera
	transmits signals from light receptors in the retina to the brain		
	fluid between the iris and the cornea; keeps the eyeball rigid and refracts light		
vitreous humour			

Goal • Assess your understanding of concepts in Topics 4-5.

What to Do

Carefully read the instructions before answering each set of questions.

Matching

Match each description in column A with the correct term in column B. Place the letter for the term on the line beside the description.

A	B
___ 1. cause parallel light rays to converge	(a) upside down
___ 2. image often formed by a double convex lens	(b) glass or plastic lens
___ 3. thick in the middle and thin around the edge	(c) double concave lens
___ 4. cause light rays to spread out	(d) double convex lens
___ 5. cause light rays to bend as they pass through	(e) right side up
___ 6. image seen through normally shaped eye	(f) convex lens
	(g) sideways

Fill in the Blanks

Complete each sentence with the correct term.

7. A _____ lens is wider in the middle than at the edges.
8. A _____ mirror shows a large field of view, but objects in the mirror look smaller and far away.
9. The _____ carries a signal from the eye to the brain.
10. The _____ is an imaginary line perpendicular to a surface.
11. The diaphragm of a camera controls the size of the _____.
12. Another name for ocular lens is _____.
13. The magnified image in a magnifying glass is a _____ image.
14. In a far-sighted person, the light from a nearby object focusses _____ the retina.

Diagrams

Answer each question in the space provided.

15. Sketch what happens to parallel light rays passing through each lens below.

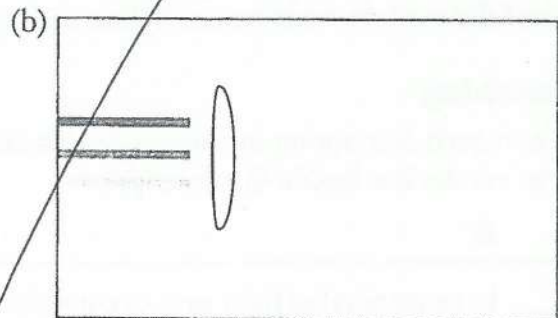
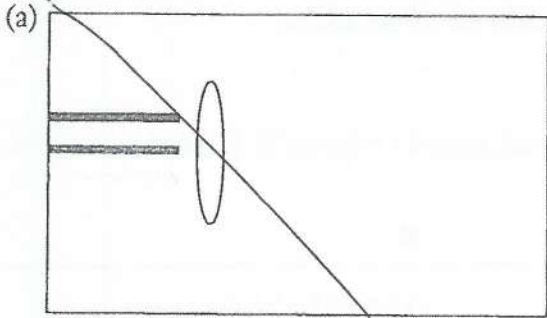

16. Label the features indicated in the diagram. Provide a caption for this diagram to identify the equipment in the diagram and its main function.

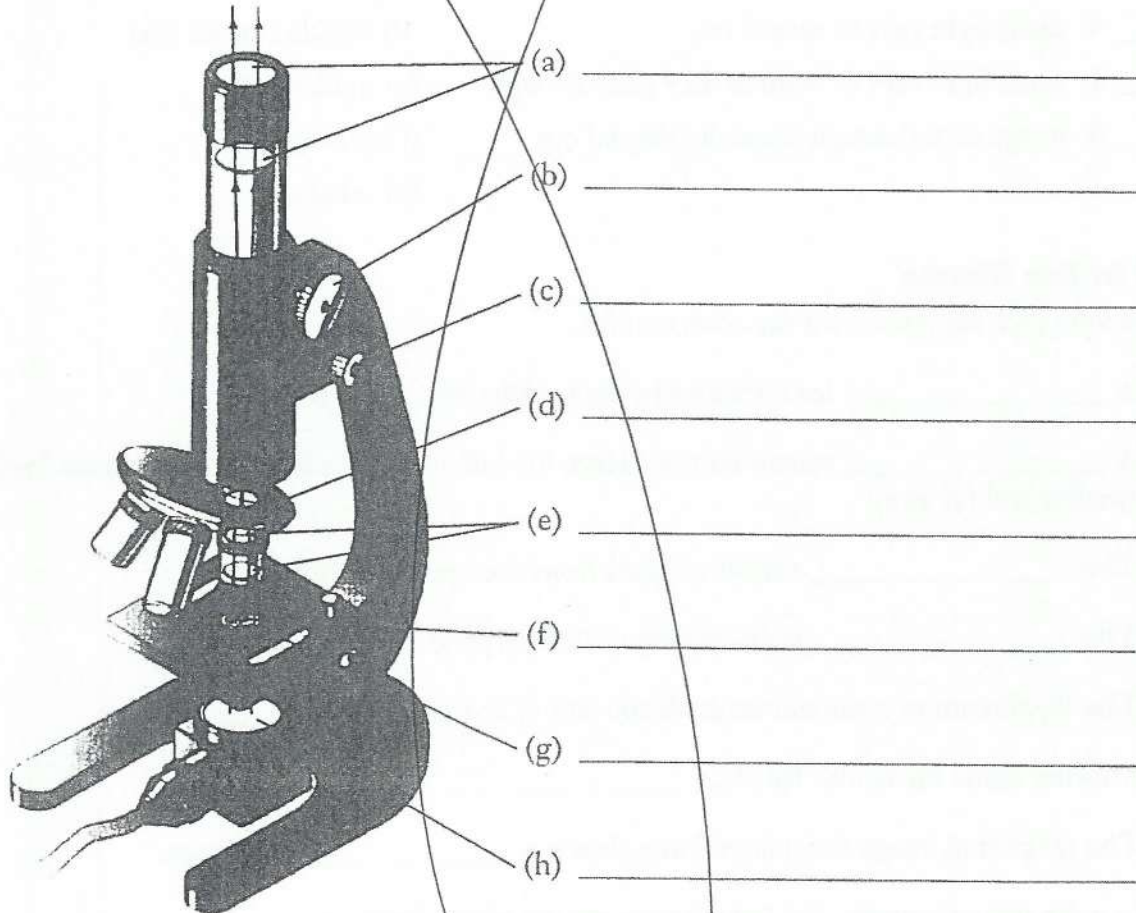

Short Answers

Answer the questions below in full sentences.

17. Describe the attitude and type of image shown in the diagram below.

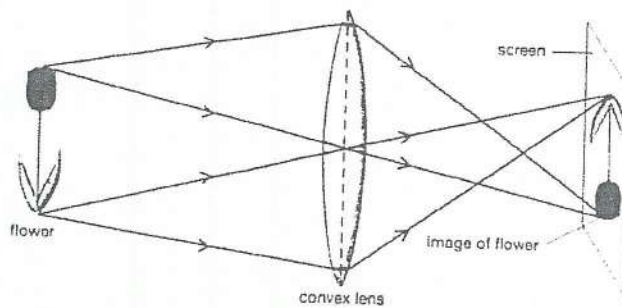

18. Describe the difference between a refracting telescope and a reflecting telescope.

Goal • Determine the wavelengths of the colours of the spectrum.

What to Do

Fill in the appropriate colours of the spectrum in the diagram below. For help, refer to the chart on page 249 of your textbook.

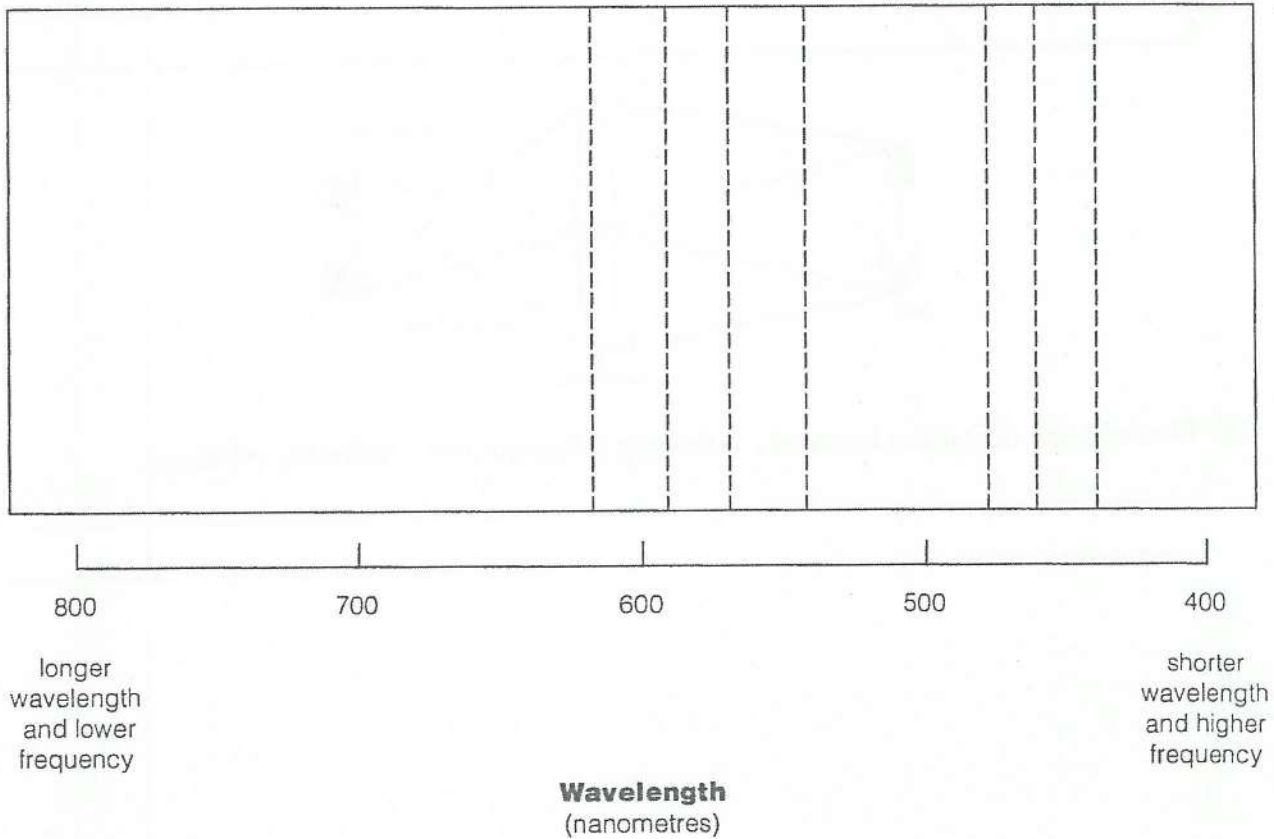

Goal • Review what happens when additive primary colours are mixed.

What to Do

The diagram below shows three coloured spotlights aimed at a screen. Choose appropriate coloured pencils to fill in the colours you would see on the screen. Refer to Figure 3.51 on page 233 of your textbook if you need help.

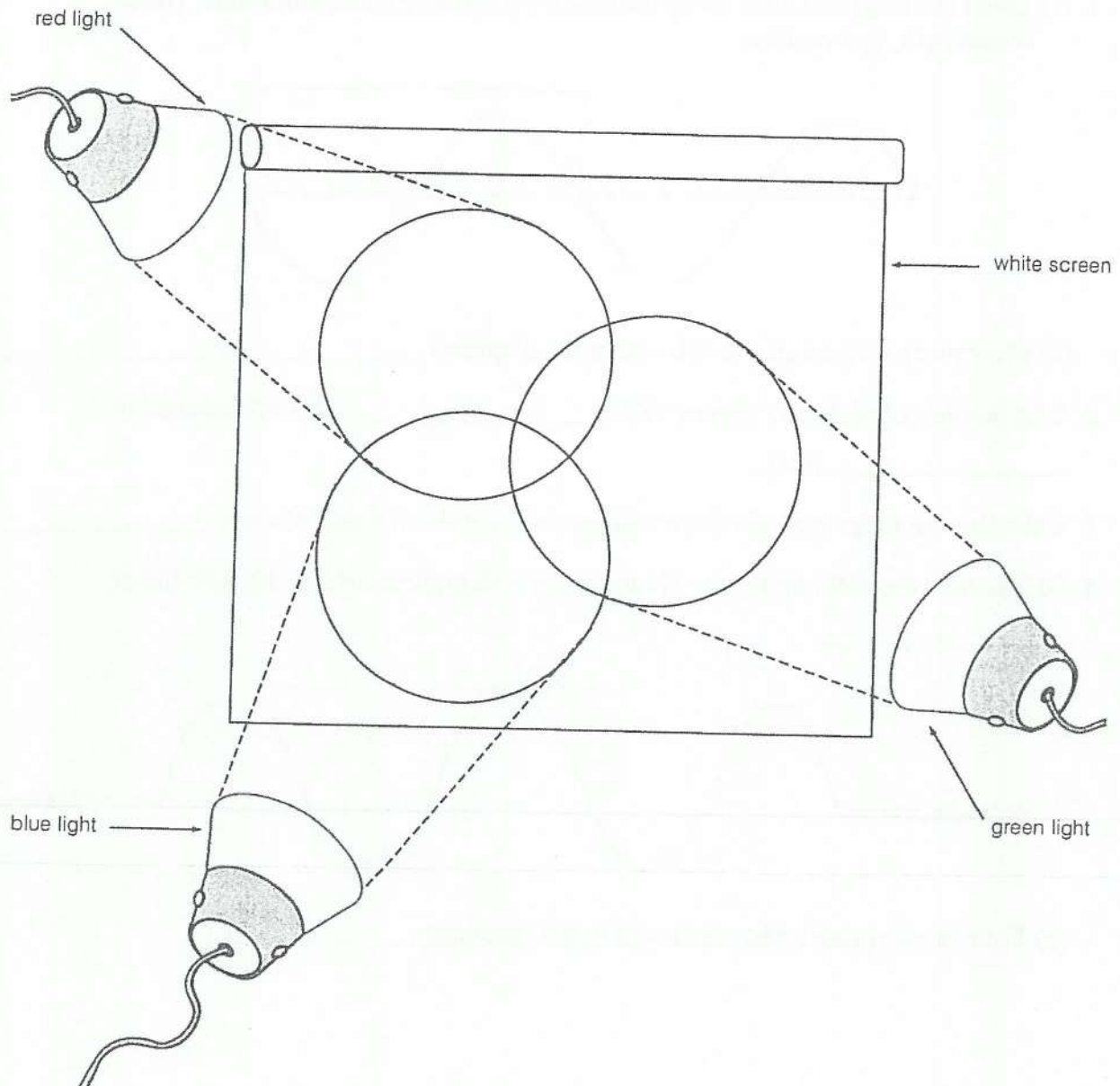

Goal • Review wave concepts.

What To Do

Answer each question in the space provided. Refer to pages 238 and 239 of your textbook if you need to review.

1. (a) Label the diagram below using the following terms: trough, amplitude, crest, wavelength, rest position.

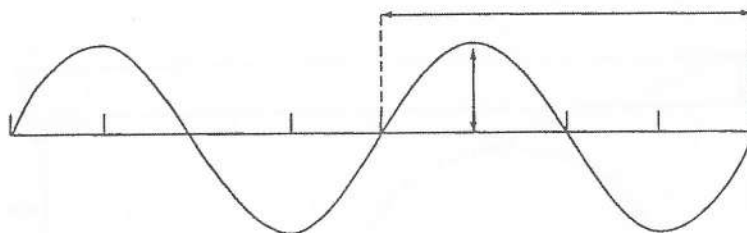

- (b) How many wavelengths are shown in the diagram? _____
2. The number of cycles per second is the _____. This is measured in _____ (Hz).
3. Calculate the frequency of a wave that goes up and down 8 times in 4 s. _____
4. (a) Examine the diagram below. How many wavelengths apart are the two ducks?

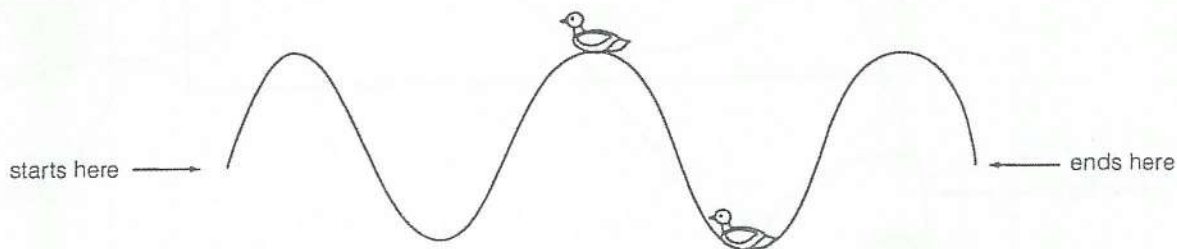

- (b) How many wavelengths are shown in the diagram? _____

Goal • Reinforce your understanding of nanometres.

Think About It

A nanometre is a very small distance. Think “nine” when you hear “nano.” If you start with 1.0 m, the decimal moves nine places to the left to get to nanometres. That is, $1 \text{ nm} = 0.000\,000\,001 \text{ m}$, which can be written as $1 \times 10^{-9} \text{ m}$. Use the table at the bottom of page 249 in your textbook to help you.

What to Do

Study the pattern in the two examples below:

- $400 \text{ nm} = 400 \times 1 \times 10^{-9} \text{ m} = 4 \times 10^{-7} \text{ m}$
- $650 \text{ nm} = 650 \times 1 \times 10^{-9} \text{ m} = 6.5 \times 10^{-7} \text{ m}$

Follow this pattern to write the wavelengths of the colours of light, in both nm and m (in two forms).

1. red = _____ nm = _____ m = _____ m
2. orange = _____ nm = _____ m = _____ m
3. yellow = _____ nm = _____ m = _____ m
4. green = _____ nm = _____ m = _____ m
5. blue = _____ nm = _____ m = _____ m
6. indigo = _____ nm = _____ m = _____ m
7. violet = _____ nm = _____ m = _____ m

The Electromagnetic Spectrum

Goal • Demonstrate an understanding of the key terms used in Topic 8.

What to Do

Use the clues provided below to complete the horizontal words in the puzzle. Then answer the questions about the two vertical words that are hidden in the puzzle.

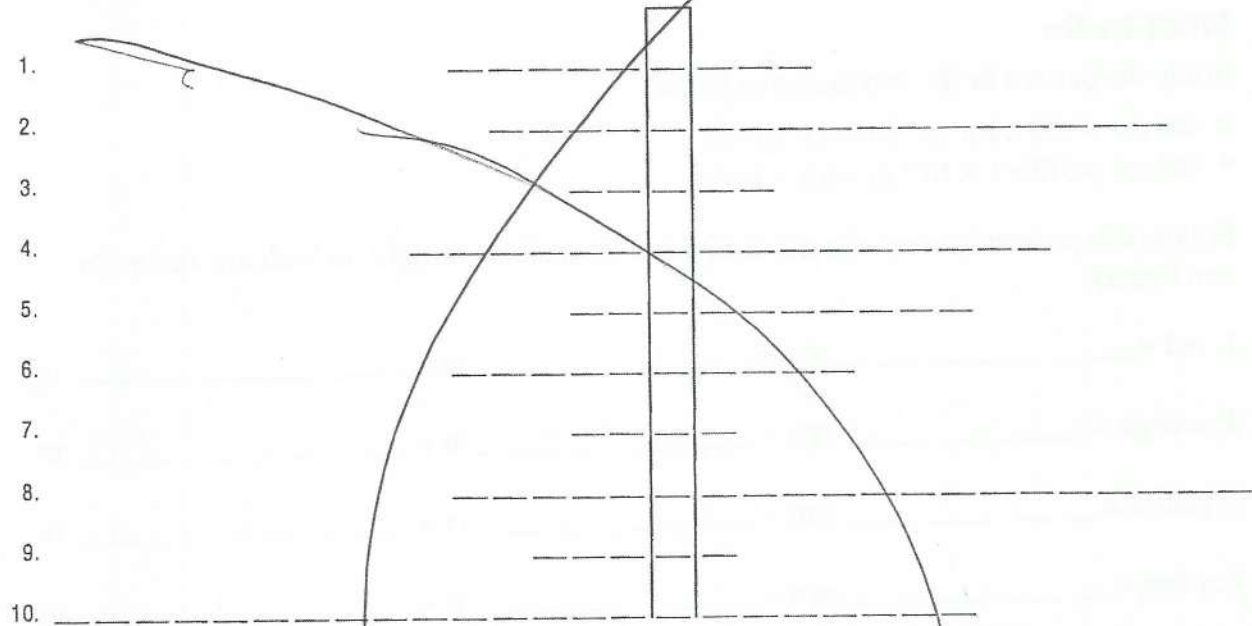

Clues

Use these clues to discover the horizontal words in the puzzle. The number after the clue tells you if the answer is one word or two. Note: There are no spaces between the words.

1. The ray with the shortest wavelength and the highest energy of all waves in the electromagnetic spectrum. (2)
2. Means "heat radiation". (2)
3. This device uses the reflection of radio waves to determine the distance and location of unseen objects. (1)
4. This technology uses gamma rays to destroy cancerous cells. (2)
5. This form of oxygen surrounds the Earth. (2)
6. Of all radio waves, these have the shortest wavelength and the highest frequency. (1)

The Electromagnetic Spectrum (continued)

7. This form of electromagnetic radiation can penetrate substances like skin and muscle. It is often used to locate a break in a bone. (1)
8. This kind of wavelength (200nm beyond violet light) causes tanning. (2)
9. This word stands for "light amplification by the stimulated emission of radiation". (1)
10. Visible light energy and all invisible forms of radiant energy exist on this spectrum. (2)

Questions

1. What are the hidden vertical words? _____
2. What does this term mean?

3. Name some uses for this technology.

Goal • Assess your understanding of concepts in Topics 6-8.

What to Do

Carefully read each set of questions before answering them in the space provided.

Fill in the Blanks

Answer the questions below using terms from the list provided.

gamma rays

radio waves

visible light

infrared radiation

ultraviolet radiation

X-rays

1. Which radiation has the shortest wavelength? _____
2. Which radiation can tan skin? _____
3. Which radiation can cause cancer? _____
4. From which radiation does the ozone layer offer protection? _____
5. Which radiation does skin sense as warmth? _____
6. Which radiation does the retina of the eye detect? _____
7. Which radiation has the longest wavelength? _____
8. Which radiation is given off in nuclear reactions? _____
9. Which radiation passes easily through skin but not through bone? _____

Diagrams

Study each diagram before answering the questions about it.

10. Examine the following wave.

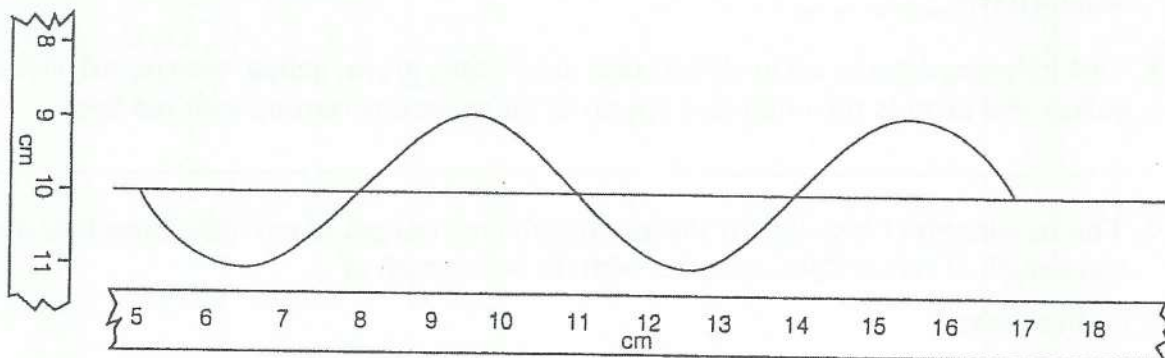

- (a) How many wavelengths long is it? _____
- (b) What is the wavelength of the wave, in cm? _____
- (c) What is the amplitude of the wave, in cm? _____

11. Compare the wave below with the wave in question 10. What features have changed? Have these features increased or decreased?

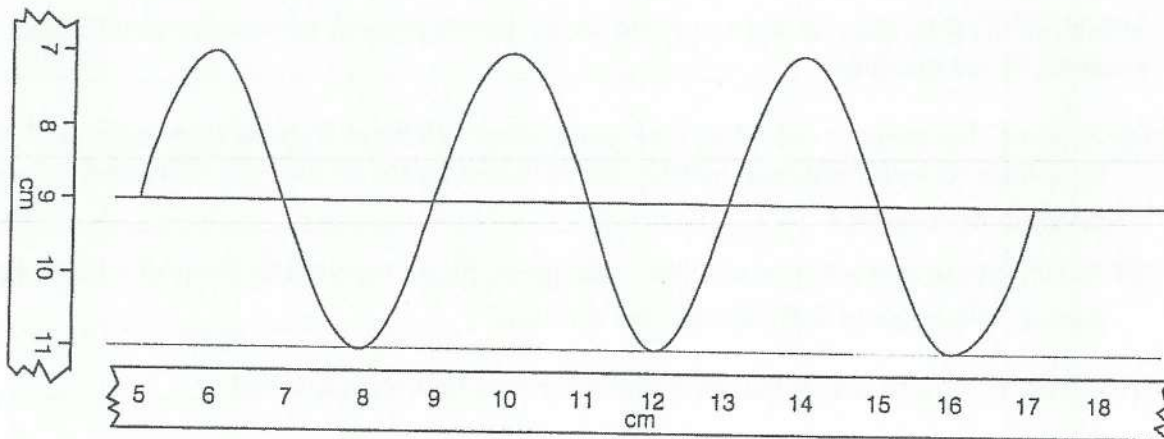

Short Answers

12. A wave goes up and down 5 times in 10 s. What is the frequency of the wave, in cycles per second (Hz)? _____
13. The following colours are in alphabetical order: blue, green, indigo, orange, red, violet, yellow. Put them in the order they appear in the spectrum, starting with red light.

14. The wavelength of blue light is shorter than the wavelength of red light. State how the wavelength of yellow light compares with the wavelength of
- (a) blue light

- (b) red light

- (c) green light

15. One triangular prism can split light into colours. Another triangular prism, placed upside down beside it, can combine the colours back into white light. What does this tell you about white light?

16. Which of the following do not use radio waves: television sets, microwave ovens, radar antenna, X-ray machines? _____
17. (a) Suppose that you put red, blue, and green colour filters in front of three separate lights (one filter to each light) and overlap the coloured lights on a screen. What colour would result in the overlap? _____
- (b) Now suppose that you put red, blue, and green filters together in front of a single light source. What colour light would pass through? _____
18. Two colours of light that, when combined, form white light are called _____
19. (a) Name the two types of light-sensitive cells in the eye. _____
- (b) Which type detects colour? _____

Use what you have learned to answer these questions.

1. Match the parts of the eye with their "partner" part of a film camera.

- | | |
|-----------|---------------|
| a. pupil | ___ developer |
| b. lens | ___ film |
| c. retina | ___ diaphragm |
| d. brain | ___ lens |

2. Complete this Venn diagram to compare our eyes to a film camera.

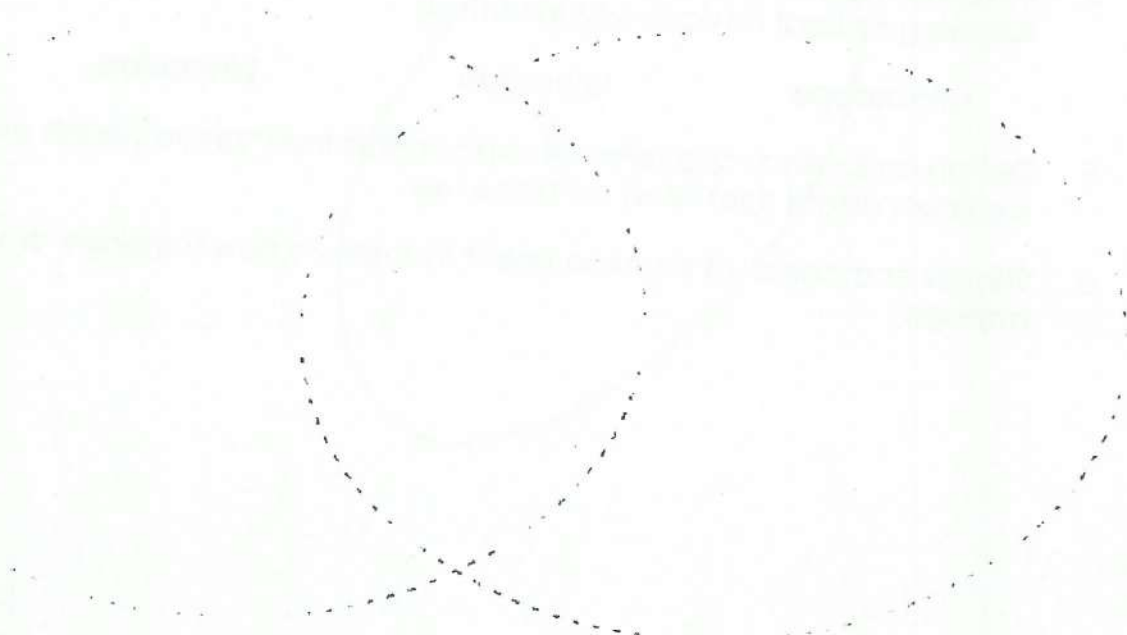

3. When a person has to wear glasses, what part of their eyes is probably not working properly? Why do you think so?

Final Project

Choose **one** of the projects below to complete alone or with a partner, and then share your work with your class.

1. Research and create a diagram that shows how one of the following animal's eyes work:

frog

house fly

fish

2. Research and create a poster that shows how laser eye surgery works.

3. Research and describe how digital cameras work.

4. Research and create a presentation that describes how and why one of the following optical devices was invented:

microscope

telescope

binoculars

5. Design and conduct a series of experiments that "prove" each of the things we know about light listed on page five.

6. Design and conduct an experiment that shows how rainbows or sunsets happen.

Name: _____

Date: _____

Science Eight
Module Three
Light and Optical Systems
Investigation #1

1. Define light:

2. Define radiation AND radiant energy:

3. In regards to energy transfer, what is the difference between radiation and sound energy?

4.

List two sources of artificial light used in homes and offices.

Name: _____

Date: _____

9.

Chemiluminescence makes glow sticks give off light.

- a. What is the energy pathway for chemiluminescence? Draw the pathway or describe it.
- b. How does this energy pathway compare to the energy pathway for photosynthesis? Explain your answer. Refer to Module 2 if necessary.

10. Compare incandescent lighting to fluorescent lighting. Which one is more environmentally friendly? Which one wastes less energy? Explain your answer.

Goal • Review terms introduced in Topic 1.

What to Do

Use the terms at the beginning of each section to complete the sentences that follow.

Fluorescence

efficient	electrical	expensive	fluorescent
hot	incandescent	phosphor	poisonous
ultraviolet	vapour	visible	

- The long tubes in overhead lights and the tubes that spell the names of stores and restaurants are examples of _____ light sources. They do not work the same way as _____ bulbs, which have filaments that heat up and glow.
- In fluorescent bulbs, _____ energy is absorbed by the particles of mercury _____ inside the tube. These particles give off _____ light (a type of light you cannot see), which hits the white _____ powder on the inside of the bulb. The phosphor particles give off _____ light.
- A disadvantage of these bulbs is that they are _____, so their contents are _____. An advantage of these bulbs is that they are energy _____ because they do not get _____.

Phosphorescence

delay	energy	glows	light
-------	--------	-------	-------

- Phosphorescence is similar to fluorescence, except the particles that absorb the _____ do not release it immediately. There is a _____. An example is a toy ball that _____ after you hold it near a bright _____ for a while.

Chemiluminescence and Bioluminescence

artificial	chemical	light	living
------------	----------	-------	--------

- Electrical and solar energy are used to make incandescent or fluorescent light. Energy released in _____ reactions provides the energy for chemiluminescence and bioluminescence. Chemiluminescence refers to _____ light produced this way. Bioluminescence refers to the _____ produced by _____ organisms.